

## Sink Diade Gun Metal Fumè

Kitchen Sinks

Code: 3028 816



### DETAILS

Edge/Installation Type	Undermount
Material	AISI 304 stainless steel
Texture	Brushed in line
Finish	Foster brushed
Finish	PVD
Coloring	Gun Metal Fumè
Base	90 cm
Width	80 cm
Dimensions	800 x 440 mm

Bowl dimension 760 x 400 mm

---

Built-in hole [View technical data sheet](#)

---

Standard fittings Fixing hooks, drain, overflow and siphon, boxed packing

---

Mixer holes No standard holes

---

Drainer No

---

Number of bowls 1 bowl

---

Waste fitting 3,5" drain

---

## FEATURES

**Basket 3,5" waste fitting** The drain is equipped with a large 3.5" drain, with the practical basket cap that prevents the discharge of solid parts.

---

**Deep bowls** This bowls reach an important depth, over 20 cm, thanks to the advanced production technology, that can be offer great capiciency and practicity in all the washing operations.

---

**GUN METAL FUMÈ** The Gun Metal Fumè finish is obtained by treating steel with a physical process called PVD (Phisical Vacuum Deposition) which deposits particles of noble metals on the surface. The result is a unique and refined aesthetic effect, and an improvement of the mechanical properties of the steel which is more resistant to impact and scratches.

---

**High thickness** 1mm thick steel. A significant thickness, which guarantees the maximum sturdiness and durability.

---

**MOULDED BOTTOM** The moulded bottom guarantees perfect water flow and facilitates cleaning operations thanks to the perimeter step with sloping walls.

---

Perimetral overflow

The overflow is always a security on the Foster sinks that prevents the overflow of water in case of oversights. The perimeter drain solution improves aesthetics thanks to its square and essential shape.

## TECHNICAL DATA

Sottotop/Under-mount  
Base 90 | 90 Cabinet

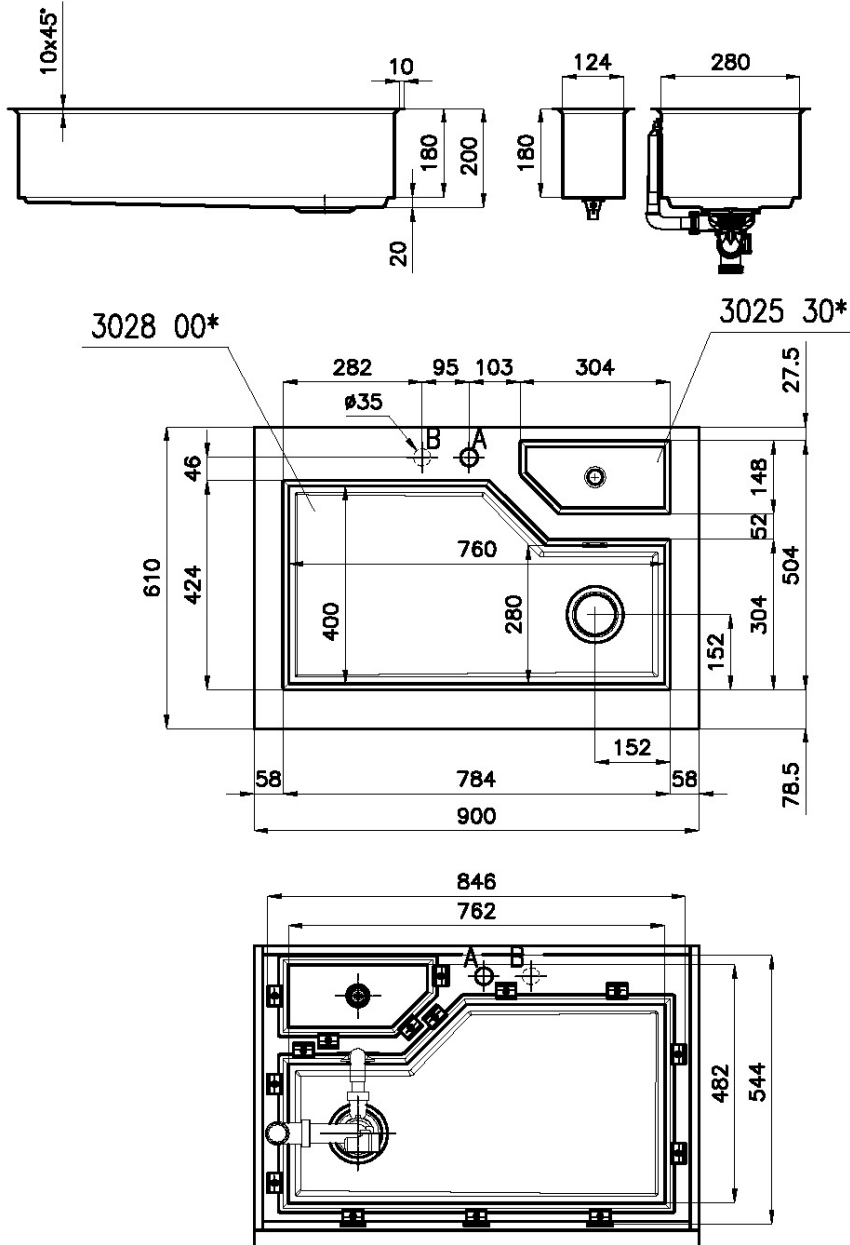

A: Foro Mix/Mixer tap cut-out

B: Foro comando automatico piletta/Automatic waste-fitting command cut-out

## Sottotop/Under-mount Base 120 | 120 Cabinet

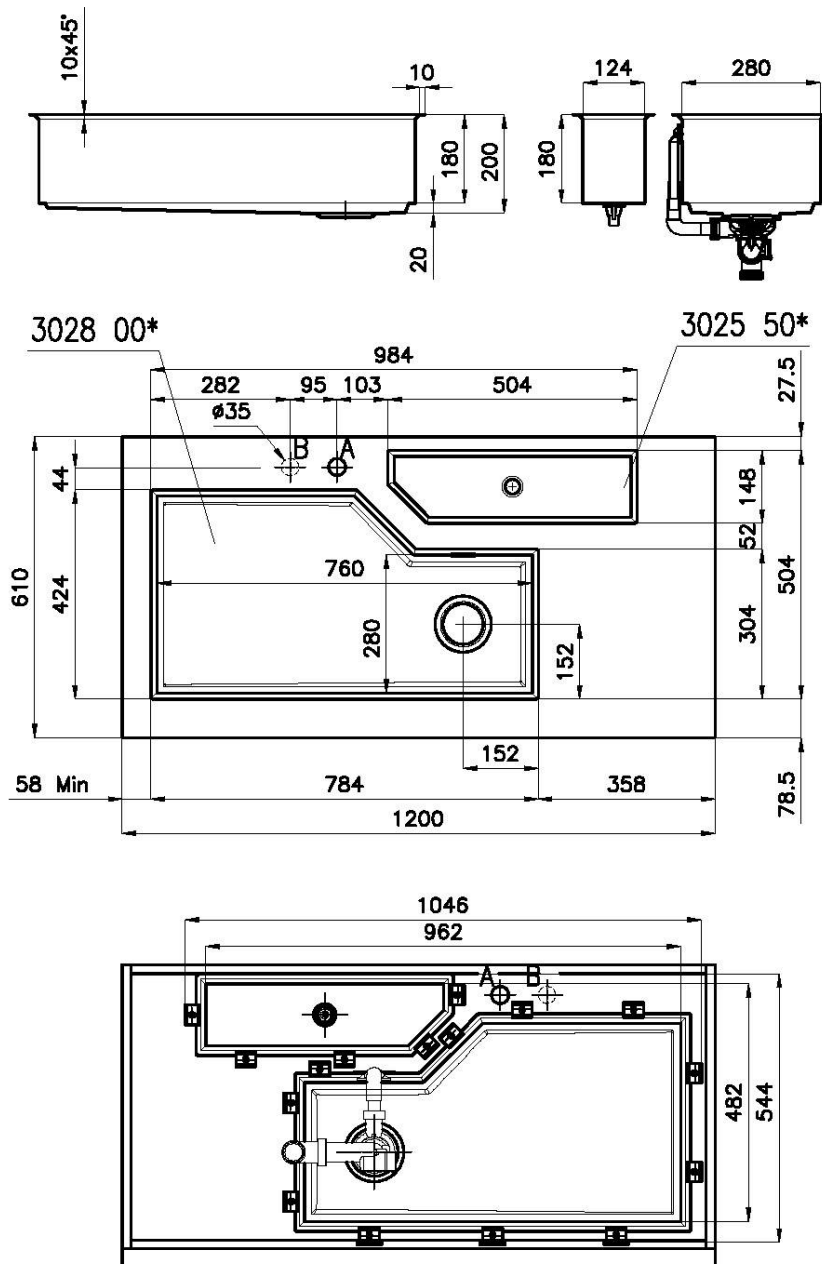

A: Foro Mix/Mixer tap cut-out

B: Foro comando automatico piletta/Automatic waste-fitting command cut-out

## Sottotop/Under-mount

### Base 90 | 90 Cabinet

Cut out size

Dimensioni per foratura top

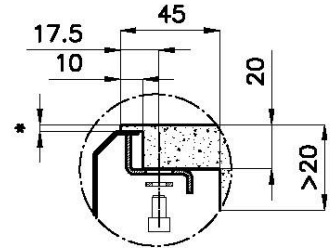
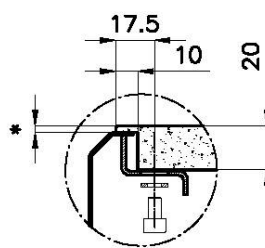
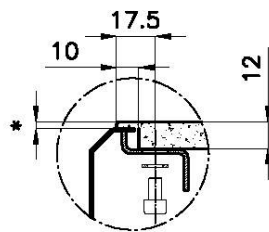
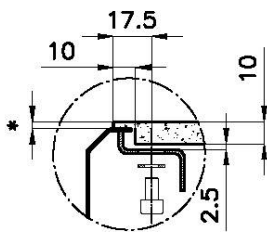
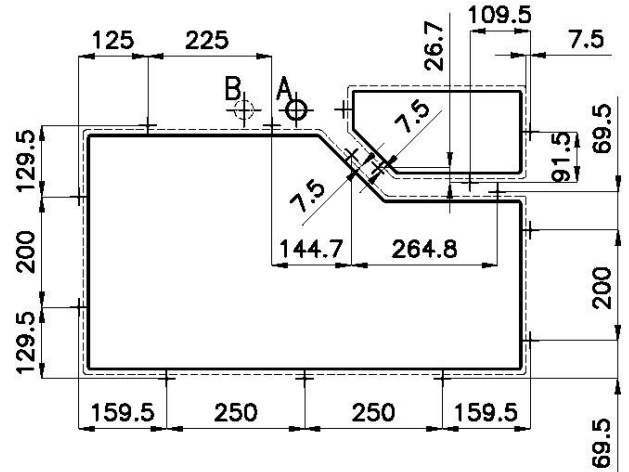
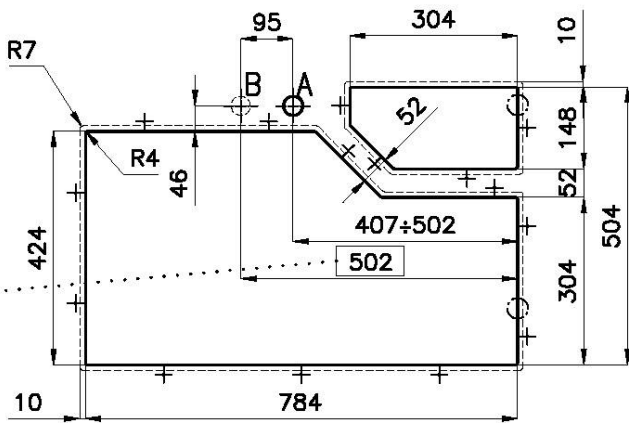

Quota max per piletta automatica / Max quote for automatic drain

\*lo spessore minimo deve essere valutato in base alla resistenza del materiale

\*Minimum thickness must be evaluated in reference to the material's resistance

sink thickness/spessore acciaio

1

## Sottotop/Under-mount Base 120 | 120 Cabinet

Cut out size  
Dimensioni per foratura top

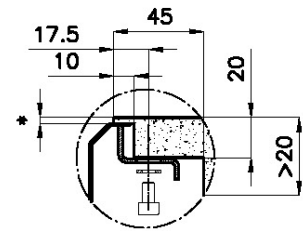
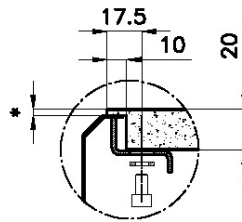
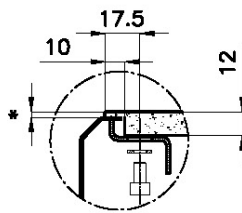
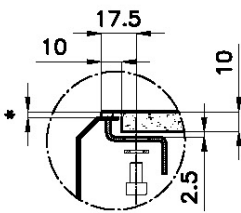
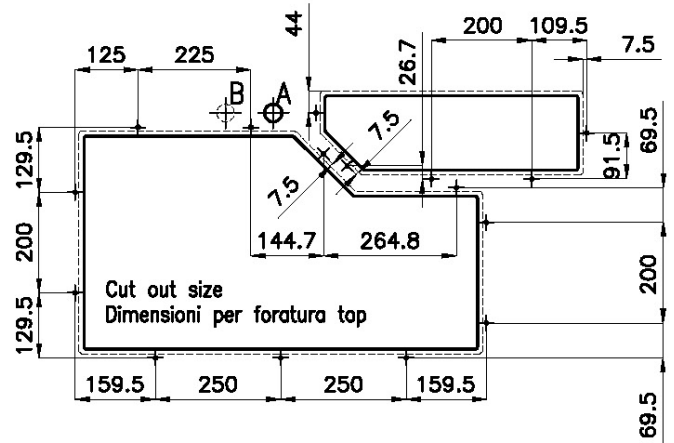
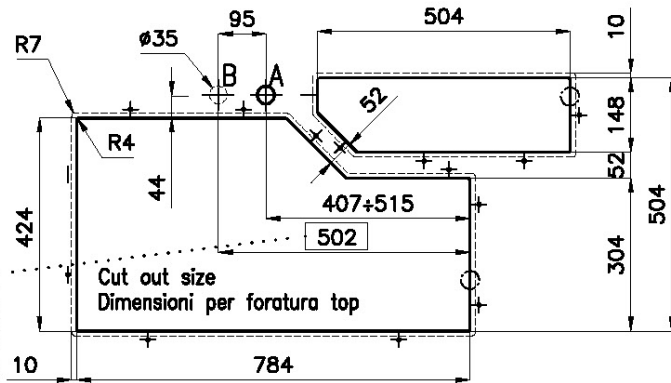

Quota max per piletta automatica / Max quote for automatic drain :

\*lo spessore minimo deve essere valutato in base alla resistenza del materiale  
\*Minimum thickness must be evaluated in reference to the material's resistance

sink thickness/spessore acciaio 1

## SOTTOTOP

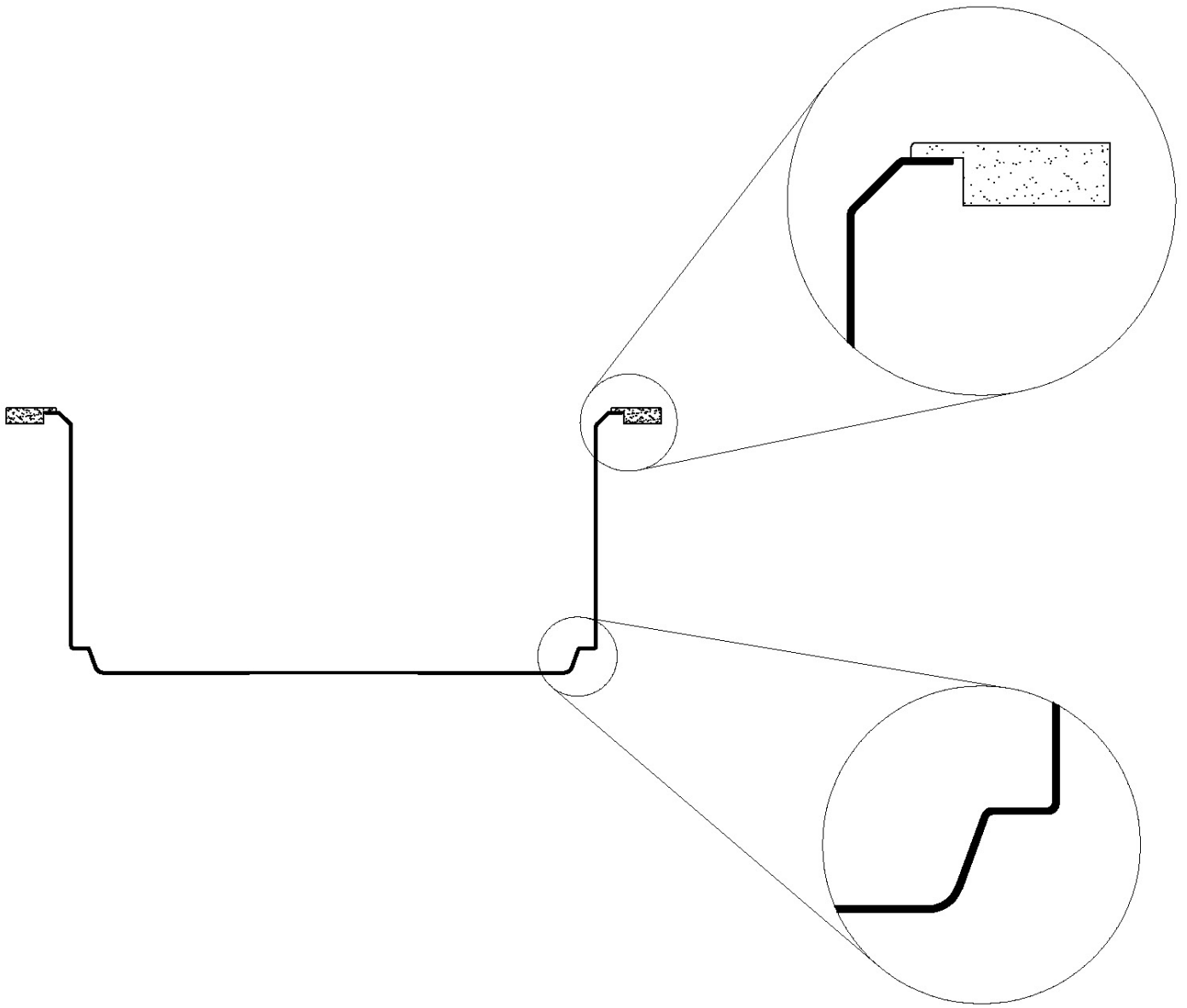

## GALLERY



## EQUIPMENT



**Black multifunction chopping board**

8100 608

## OPTIONAL ACCESSORIES



**Stainless steel perforated tray**

8151 001



**Black lid**

8151 005



**Stainless steel colander**

8151 010



**Iroko-wood round chopping board**

8642 005



## RECOMMENDED PAIRINGS



**VOLTA GUN METAL**  
8491 106



**Dispenser Evo satin Gun Metal**  
8520 156



**Diade equipped troughs Gun Metal  
Fumè**  
8100 136



**Diade equipped troughs Gun Metal  
Fumè**  
8100 156



**Diade equipped troughs Gun Metal  
Fumè**  
8100 166

## OPTIONAL AUTOMATIC WASTE FITTINGS



**Space Push Gun Metal automatic  
waste fitting - PO**  
8407 120